

LoPro[®] Linear Motion Systems

built with **DUALVEE[®]** Motion Technology[®]

WIPER LEAD/BALL SCREW DRIVEN SYSTEM MANUAL

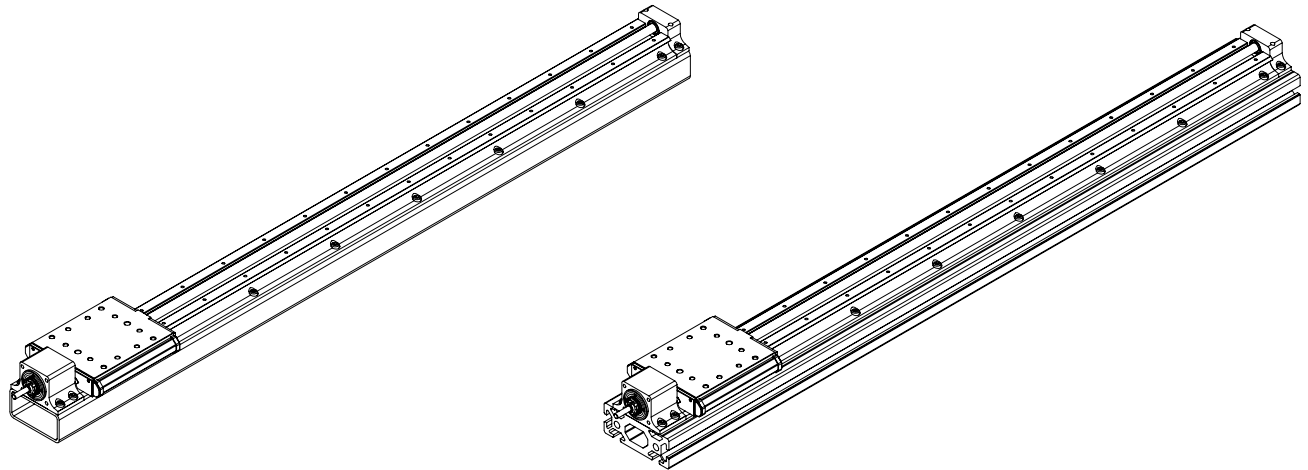
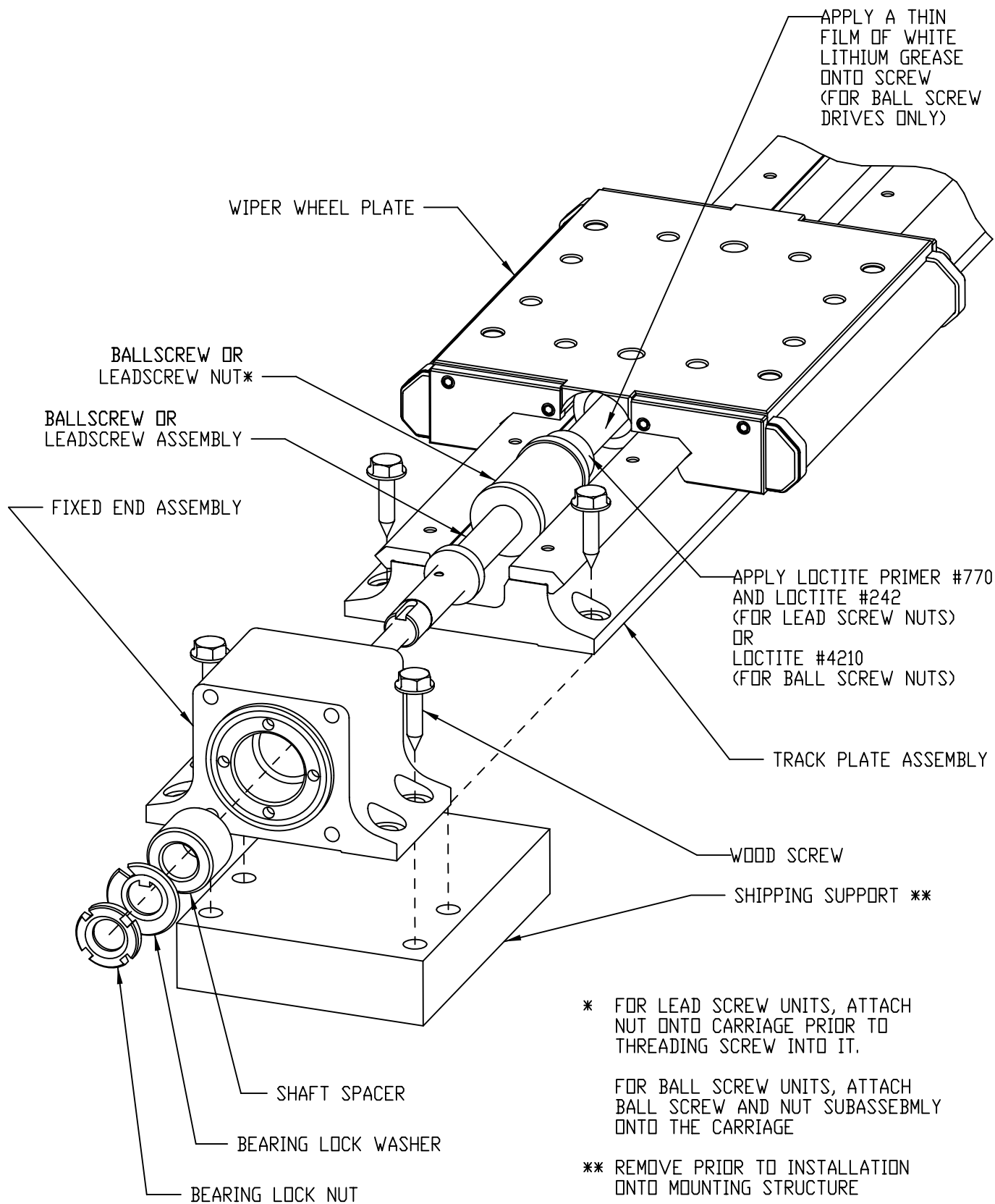

LoPro® WIPER BALLSCREW/LEADSCREW SYSTEM



LoPro® WIPER BALLSCREW/LEADSCREW SYSTEM

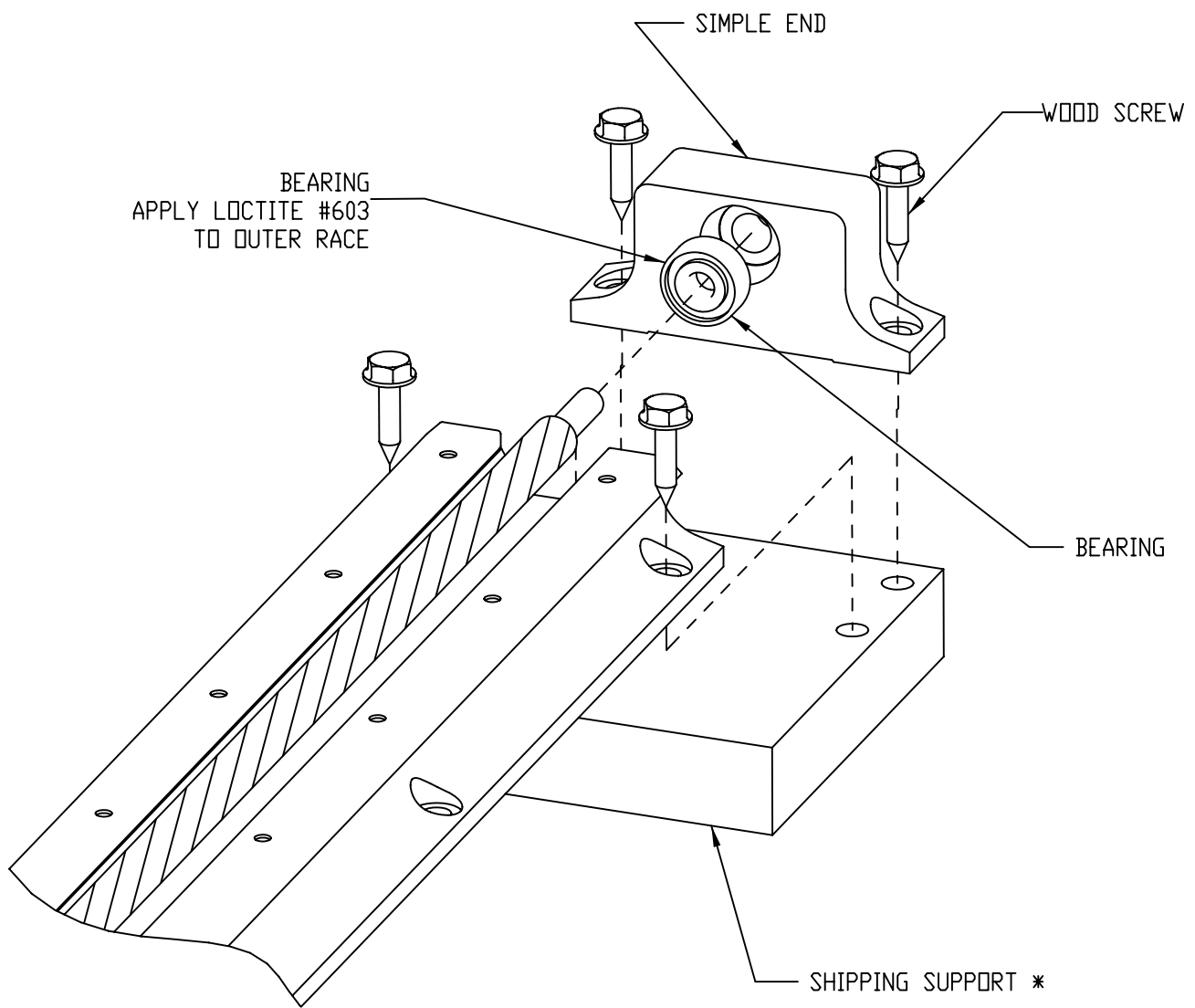

* REMOVE PRIOR TO INSTALLATION
ONTO MOUNTING STRUCTURE

LoPro® WIPER WHEEL PLATE MAINTENANCE

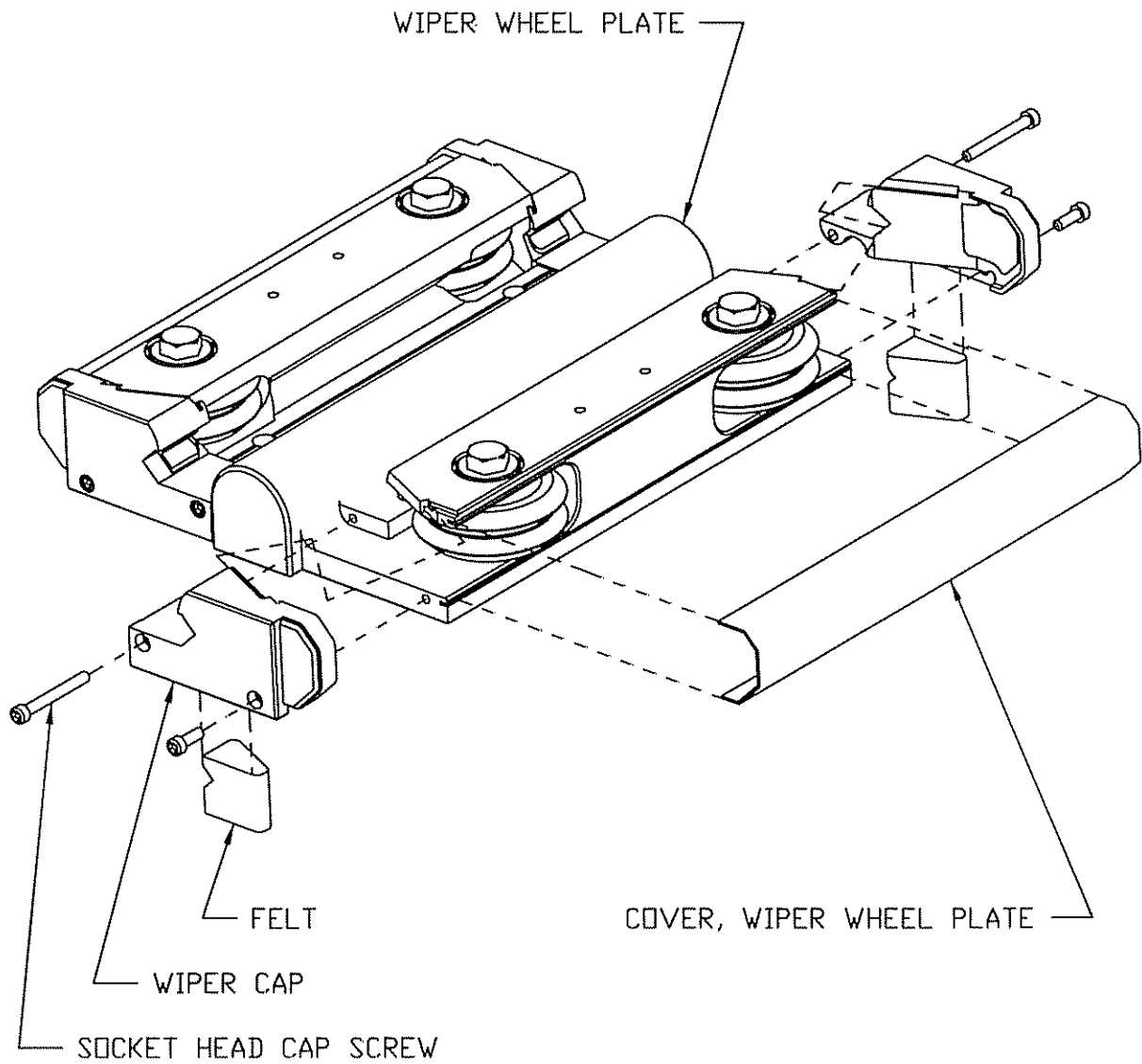

LoPro® WIPER WHEEL PLATE MAINTENANCE

ECCENTRIC BUSHING ADJUSTMENT

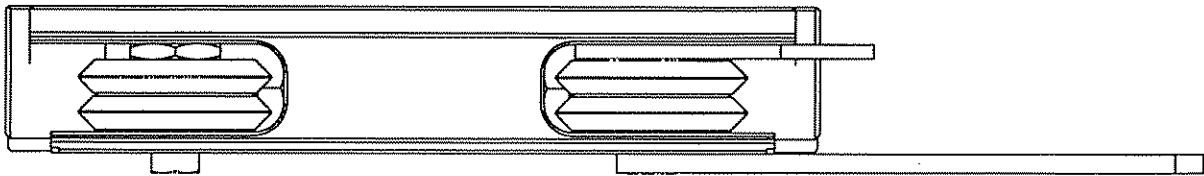
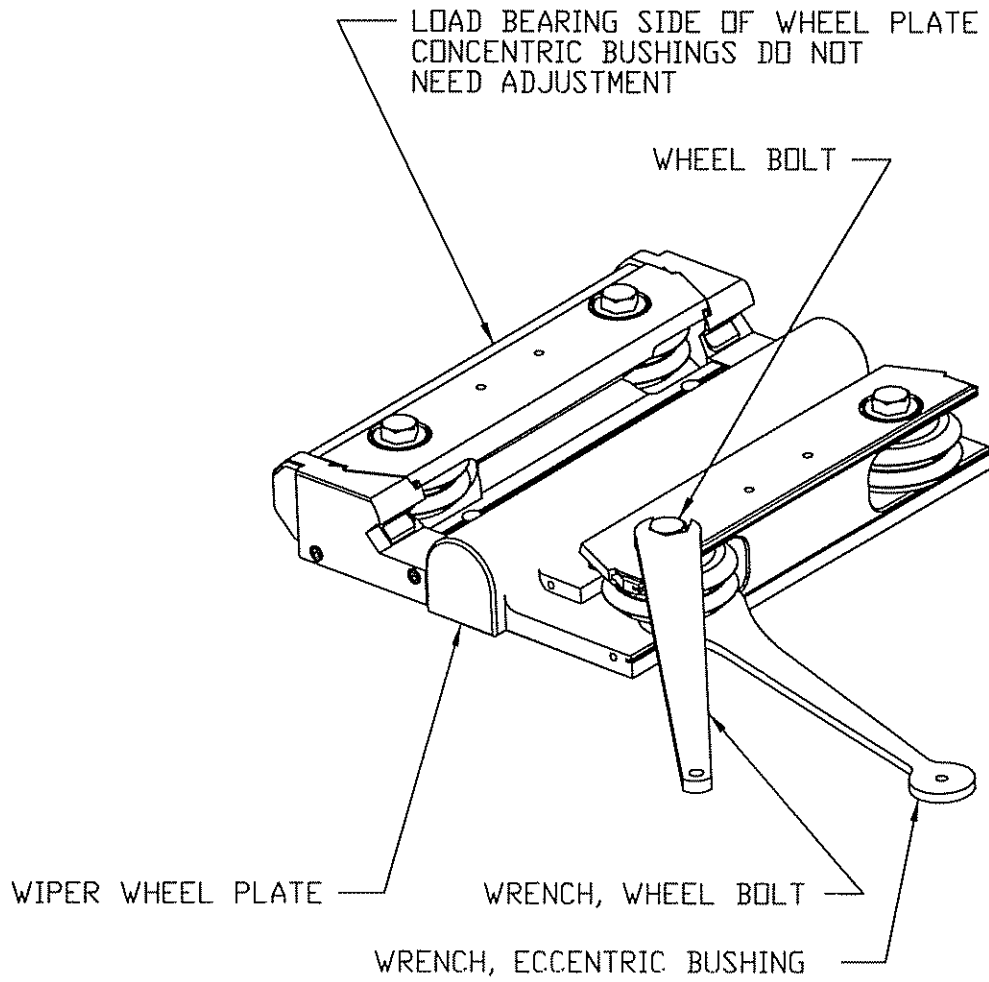

LoPro® DUAL VEE® WHEEL FIT-UP

TO OBTAIN THE BEST PERFORMANCE FROM A Bishop-Wisecarver LoPro LINEAR MOTION SYSTEM, CARE SHOULD BE TAKEN TO ENSURE THE WHEEL PLATE IS CORRECTLY ADJUSTED.

ADJUSTMENT OF PRELOAD FOR GUIDE WHEELS WITH BUSHINGS:

THE GUIDE WHEELS ARE FASTENED TO THE WHEEL PLATE WITH SPECIAL MOUNTING BOLTS. THESE BOLTS PASS THROUGH SHOULDERED BUSHINGS THAT ARE INSERTED INTO THE GUIDE WHEEL. THERE ARE TWO TYPES OF BUSHINGS; THE FIXED OR CONCENTRIC, AND THE ADJUSTABLE OR ECCENTRIC. THE ECCENTRIC BUSHING HAS HEXAGONAL WRENCH FLATS.

1. CHECK CONCENTRIC GUIDE WHEEL MOUNTING BOLTS FOR TIGHTNESS.
2. LOOSEN THE ECCENTRIC GUIDE WHEEL MOUNTING BOLT JUST ENOUGH TO ALLOW ROTATION OF THE ECCENTRIC BUSHING. MAKE THE FOLLOWING ADJUSTMENTS IN SMALL INCREMENTS.
3. PLACE THE LoPro ECCENTRIC WRENCH ON THE ECCENTRIC BUSHING AND ROTATE THE HANDLE AWAY FROM THE CENTER OF THE WHEEL PLATE TO A POINT WHERE THE GUIDE WHEELS CONTACT THE TRACK.
4. HOLD THE GUIDE WHEEL FIRMLY BETWEEN YOUR FINGERS AND MOVE THE WHEEL PLATE ALONG THE TRACK. AT THE SAME TIME, ROTATE THE BUSHING TO A POINT WHERE THE GUIDE WHEEL DOES NOT SKID ON THE TRACK. TIGHTEN THE WHEELBOLT SNUGLY SO THAT THIS TEMPORARY ADJUSTMENT WILL HOLD.
5. REPEAT THIS PROCEDURE ON THE SECOND ECCENTRIC GUIDE WHEEL.
6. A PROPER ADJUSTMENT IS ACHIEVED BY REPEATING STEPS 4 AND 5 UNTIL A UNIFORM RESISTANCE TO MOTION IS ATTAINED BY "FEEL" ALONG THE ENTIRE TRACK.
7. FULLY TIGHTEN THE ECCENTRIC WHEEL BOLTS TO FIX BOTH ADJUSTMENTS. NOTE THAT BOTH ECCENTRIC WHEELS NEED TO BE ADJUSTED PRIOR TO PERFORMING THIS FINAL TIGHTENING SO AS TO AVOID BINDING OF THE CARRIAGE.
8. APPLY WICKING THREAD LOCKER TO WHEEL BOLT THREADS FROM TOP OF WHEEL PLATE. USE LOCTITE 290 OR EQUIVALENT.

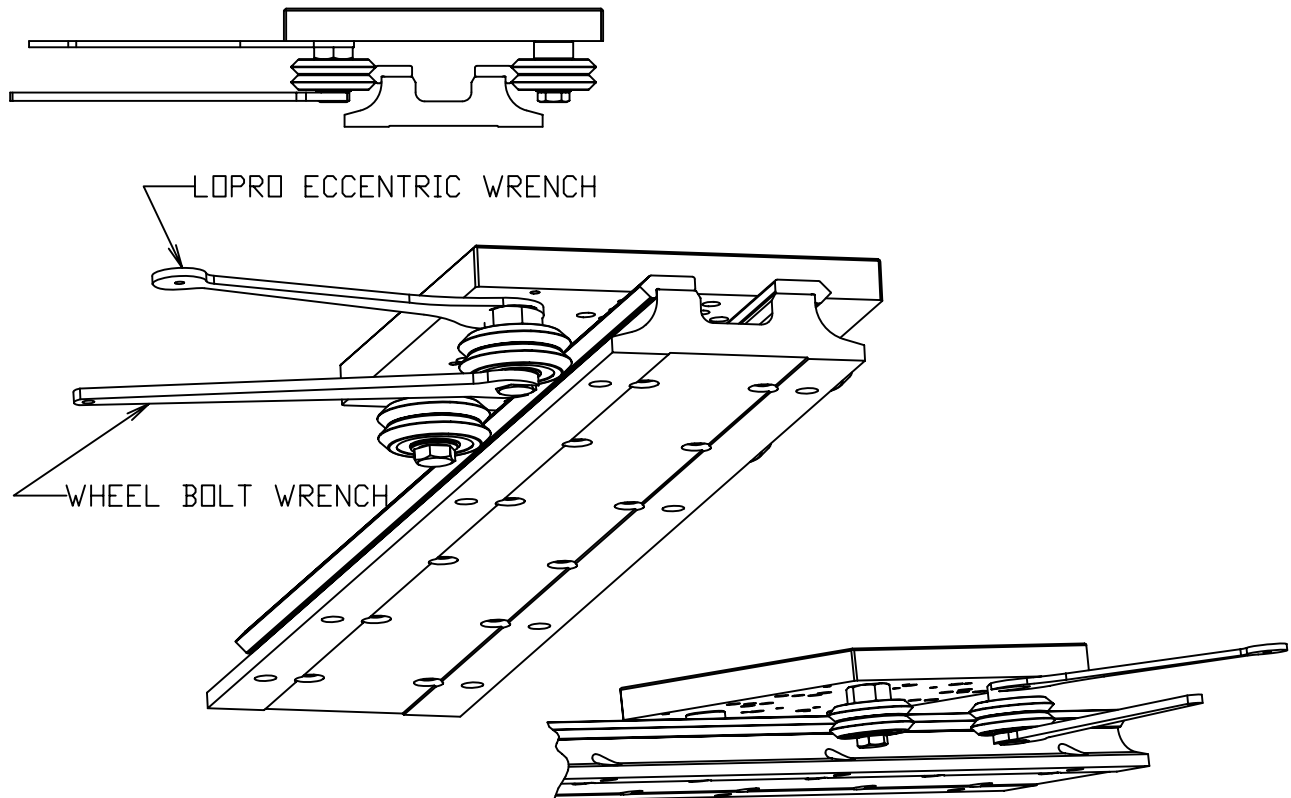

LoPro® TRACK PLATE MAINTENANCE

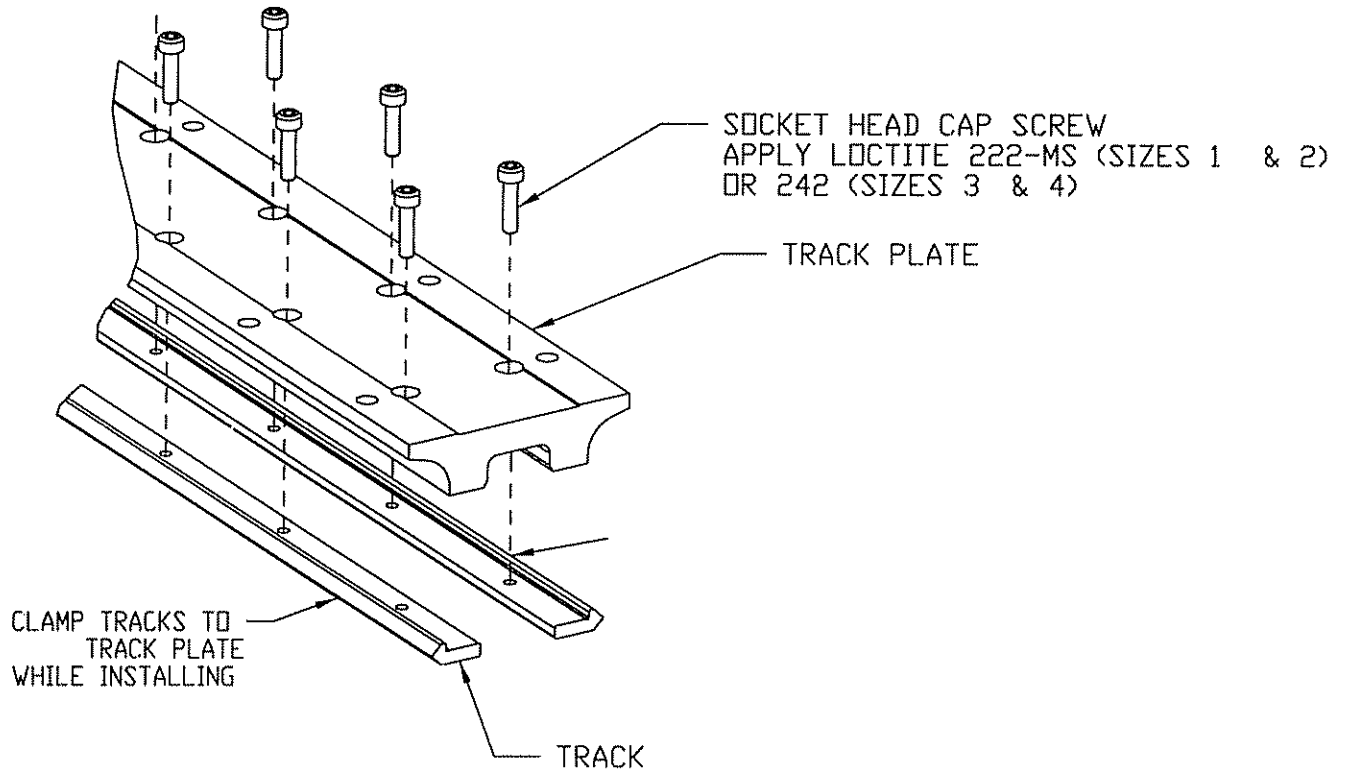
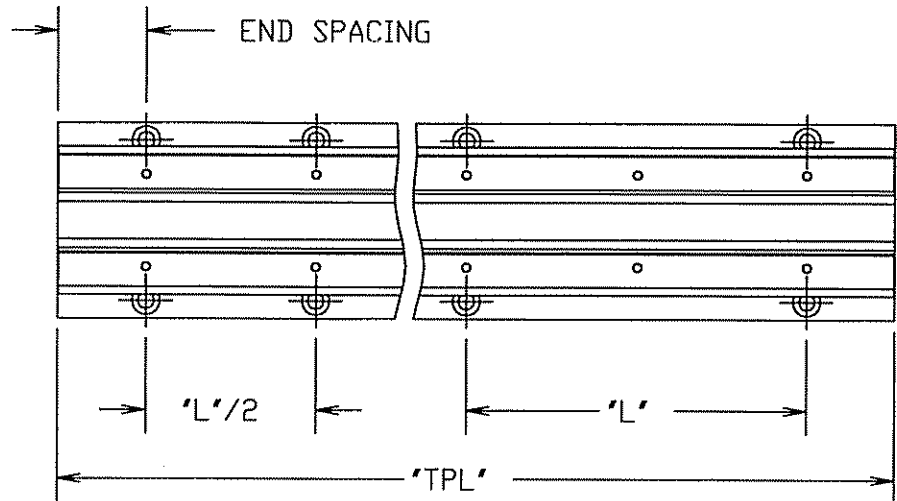

TO DETERMINE HALF HOLE AND END SPACES:

TPL = TRACK PLATE LENGTH
L = TRACK PLATE MOUNTING HOLE SPACING

$[(TPL \times 2) / L] - .36$ = INTEGER NUMBER AND DECIMAL VALUE
 INTEGER NUMBER/2 = NUMBER OF SPACES
 A VALUE WITH .5 REPRESENTS A HALF HOLE
 $[(DECIMAL VALUE + .36) \times L/2] / 2$ = END SPACES