

Whitepaper

Considerations for Adding Linear Guide Features to Industrial Equipment

INTRODUCTION

Numerous factors must be considered when adding a linear guide feature to a piece of industrial equipment. Among these are the type of linear guide product and the components already present in the equipment for the linear guide features to be mounted on. Traditional linear guide products such as plain bearings, linear bearings, and profile rails (Figure 3) all have varying mounting characteristics and requirements, though all require more machining and labor than new alternatives. Within this white paper, we will examine considerations for adding linear guide features to industrial equipment, including an exploration of conventional methods as well as newer alternatives that can offer assembly advantages.

LINEAR GUIDE SYSTEMS

Linear guide features are common requirements in industrial equipment that have moving elements, such as translating stages. Linear guide features support the weight and externally applied loads (i.e., payload) on moving elements and ensure smooth, low drag motion along desired trajectories. Adding linear guide features to a piece of industrial equipment can add complexity to the design and fabrication of new systems, and to the retrofit of existing units.

DEFINITION

A **translating stage** is a component of a motion system used to restrict an object to a single axis of motion

In order for linear guides to be added to a piece of equipment, there must be features or components in the equipment's stationary and mobile elements for the linear guide components to be mounted to. Typically, such components and features are not pre-existing and require additional and specific design and fabrication work. Incorporating linear guide features into equipment constructed from T-slot extrusions (Figure 1) can be somewhat easier as the T-slots are pre-existing features that can be used to mount the linear guide rails.

T-SLOT EXTRUSIONS

T-slot profile extrusions are a popular choice among equipment builders and designers for constructing industrial equipment, frames and structures. T-slot extrusions and their associated hardware provide users with modular mounting options that permit quick and easy assembly. The continuous length T-slots, in combination with specially designed but readily available T-slot mounting fasteners and accessories, provide equipment builders and designers with nearly endless possibilities in the mounting position and design of their system components. They are relatively inexpensive, readily available from numerous manufacturers, and are offered in a wide range of shapes and sizes to meet a variety of specific user requirements. In many cases, the only machining work required to make T-slot extrusions (Figure 1) fit into applications is cutting them to

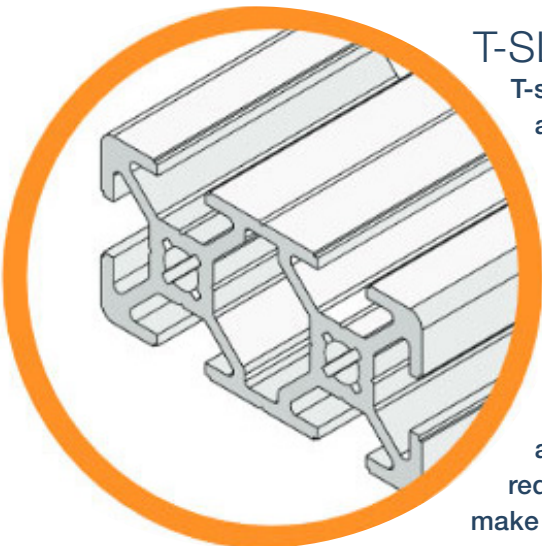

Figure 1. Aluminum Extrusion
Cross-section

application-specific lengths. As a result, T-slot extrusions (Figure 1) can provide many of the same framing and component mounting functions as custom designed and machined equipment parts, but with lower material, design and fabrication costs.

TRADITIONAL LINEAR GUIDE PRODUCTS

Physical differences among popular linear guide products such as plain bearings, linear bearings and profile rails (Figure 3) affect their mounting characteristics and requirements. As a result, the choice of linear guide products can affect the complexity and effort required to add linear guide features to a piece of equipment.

Linear Bearings and Plain Bearings

Linear bearings and the most common plain bearings are shaped like short round tubes and run on simple, round rail shafts (Figure 2). These types of shafts generally cannot be easily or directly mounted to typical equipment components, even ones made from T-slot extrusions (Figure 1). Round rail shafts (Figure 2) typically require intermediate, specially designed mounting blocks in order to be attached to a mounting surface. In addition to requiring additional components and design and fabrication work, round rails can only be mounted or supported at sections that the bearings are not required to travel over, usually at the ends of the rails. This can make high load, long travel length systems infeasible since long, unsupported shaft spans can experience significant deflection even under light loads. The bearings also often require intermediate, specially designed mounting blocks to be attached to mobile equipment payload. For example, tube-shaped linear and plain bearings require cylindrical bores for mounting and also generally require snap rings for constraint.

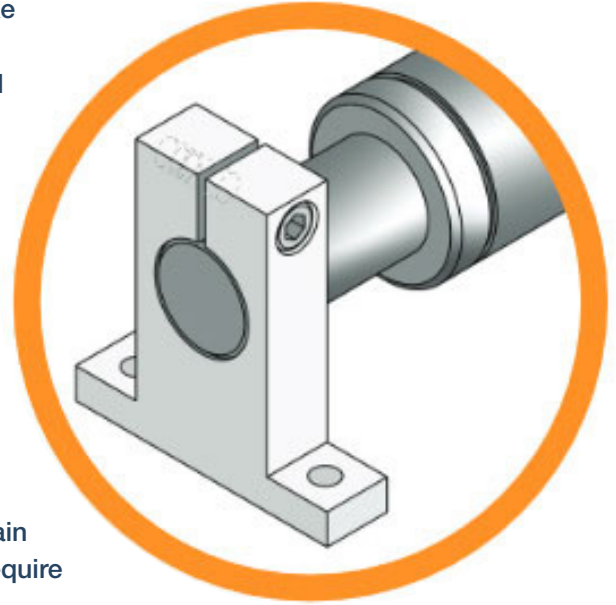

Figure 2. Round Rail

Profile Rail Systems

The rails and sliding blocks in profile rail systems have roughly rectangular cross-sectional profiles and flat mounting surfaces. This permits the rails to be easily mounted over T-slots, or any other flat surface on the machine with suitable sets of mounting holes. Unlike the round rails used for many linear and plain bearings, profile rails (Figure 3) can be fastened and supported along their entire lengths, which enhances their rigidity and strength. Profile rail (Figure 3) blocks generally have conventional mounting holes that enable payload mounting components to have simpler design and fabrication requirements than those designed for many linear and plain bearings. Nevertheless, custom design effort is still required to ensure that payload mounting components have properly sized and located mounting holes to match those on the intended profile rail blocks. If the linear guide system requires more than one block and rail, the mounting holes must also be positioned to match their intended spans. Fabrication of these custom payload mounting components can quickly become complex and costly if they need to accommodate numerous blocks and large spans between them.

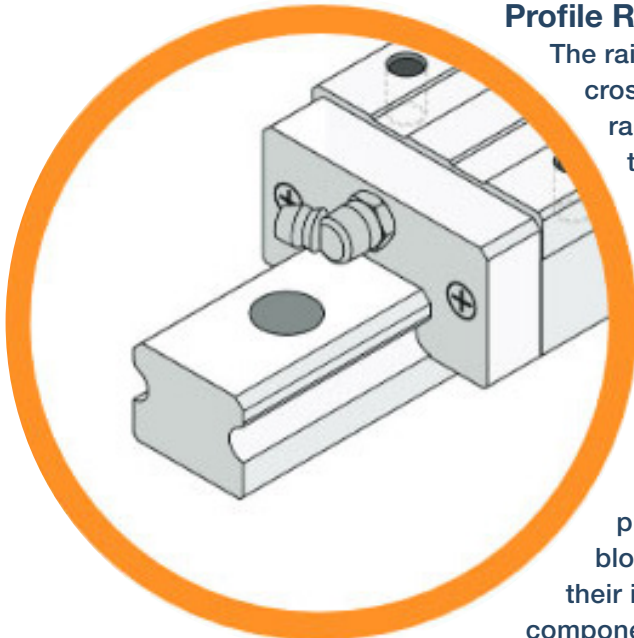

Figure 3. Profile Rail

Profile Rail Alignment

Equipment builders and designers sometimes require the linear guide systems in their equipment to feature parallel pairs of rails to meet certain design payload requirements, such as high load capacity and stiffness characteristics, as well as wide payload spans. In such paired systems, precise parallel alignment of the rails is essential for proper functionality, regardless of linear guide product type. Parallel misalignment can cause binding or looseness to develop between the linear guide rails and the mobile linear guide components (the bearings in the linear and plain bearing guide systems and the blocks in profile rails systems) as the payload moves. The linear guide product types described above generally do not have features that permit easy parallel alignment when used in paired arrangements. Parallel alignment generally must be done by machining alignment features into the linear guide mounting component surface, fabricating additional equipment components specifically for alignment, or using dedicated alignment jigs when assembling the linear guide pairs into the equipment.

A NEW LINEAR GUIDE ALTERNATIVE

QuickTrak® is a new alternative to linear bearings, plain bearings and profile rails (Figure 3). The patent pending product line includes payload-mounting wheel plate assemblies and track supports for them to run on. This modular, DualVee® guide wheel based product line was specifically developed to simplify and expedite the design and assembly processes necessary to incorporate linear guide systems into equipment. QuickTrak can be used in nearly any industrial equipment requiring linear guide features and offers pronounced installation advantages in equipment with T-slot extrusion construction.

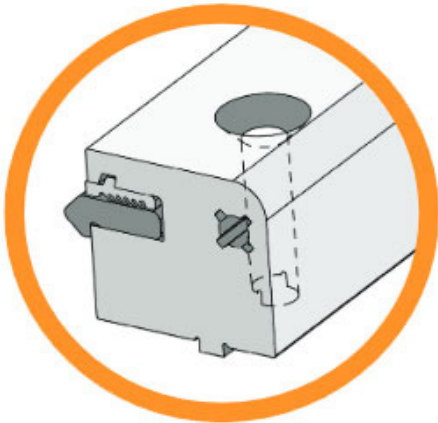

Track Support Fabrication

QuickTrak track supports consist of hardened steel DualVee track inserted and permanently mounted within extruded aluminum supports. These supports serve as mounting surface adapters for the track and have surface profiles that make it easier to mount DualVee track to typical equipment components and position the track high enough above the mounting surface for DualVee wheels to fit and be used. Most importantly, these supports provide precise alignment features to ensure optimal parallel alignment between a pair of DualVee tracks used within a system.

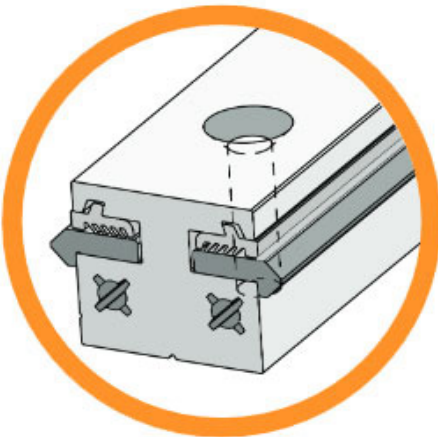

Track Support Designs: Single-Edge and Double-Edge

Two track support designs are available: single-edge and double-edge (Figure 4). Double-edge track supports (Figure 4) are designed to be used individually while single-edge track supports (Figure 4) are designed to be used in parallel pairs. Each double-edge track support (Figure 4) contains an opposing pair of DualVee track in precise parallel alignment and has a flat mounting surface that enables it to be assembled over a T-slot or a flat equipment component surface. Each single-edge track support (Figure 4) contains one DualVee track and has a special mounting surface feature designed to facilitate the alignment of paired sets. Both types of track are designed to be mounted with standard metric flat head screws. T-nuts are also used if the track supports are T-slot mounted and regular nuts may be used if the track supports are mounted to flat surfaces with clearance mounting holes.

Figure 4. Single-edge and Double-edge Track

The mounting surface on a single-edge track support is mostly flat but features a protruding step, roughly in line with its mounting holes, that is used as an alignment feature. When a single-edge track support is assembled onto a T-slot, the alignment edge is inserted into the T-slot channel and registered against the T-slot edge opposite the DualVee track to ensure parallelism between the track and T-slot, and to prevent movement even when subjected to high radial loads. For pairs of single-edge track supports assembled in parallel T-slots, this design feature enables quick and easy assembly with assured parallelism.

Single-edge track supports can also be assembled onto equipment components with flat surfaces, provided that a suitable channel for accommodating the alignment edge and mounting holes are machined into the surface. While the necessity for a machined channel (Figure 5) to accommodate a single-edge QuickTrak track support (Figure 4) may create a disadvantage when compared to a profile rail (Figure 3) which does not require such a feature, in the long run, the lack of alignment features on profile rails makes pair alignment much more difficult in systems that require paired linear guide units.

The benefits of T-slot components for building equipment as explained earlier are the same benefits which are the driving force behind the design of QuickTrak wheel plate assemblies. The wheel plates in QuickTrak wheel plate assemblies are custom T-slot extrusions that are thinner and wider than most commonly available T-slot extrusions; this enables QuickTrak wheel plate assemblies to be low profile yet offer a wide surface for payload mounting. The wheel plates are cut to user specified widths from long extrusion stock (Figure 1). Users mount their payload to the T-slots, which are designed to accommodate commonly available T-slot hardware. The DualVee guide wheels, associated components and brake kits are also mounted to the wheel plate.

T-slots with T-slot hardware. Consequently, QuickTrak wheel plate assemblies can be constructed by users with simple hand tools, negating the requirement of any user-designed and machined components. The T-slot based design also enables modifications to be easily and quickly performed. For example, if the wheel plate width needs to be altered, this can be accomplished by cutting the existing wheel plate shorter. If a wider wheel plate is desired, having a new one cut to the required length and reinstalling the wheel components on it can be completed easily. If the mounting position of the payload on the wheel plate needs to be changed, this could be done by simply moving the payload mounting T-slot hardware to new locations in the wheel plate T-slots, or by changing mounting hardware.

In contrast, implementing any of these types of changes when other linear guide product types are used would require more time consuming and costly re-design and re-fabrication of payload mounting components.

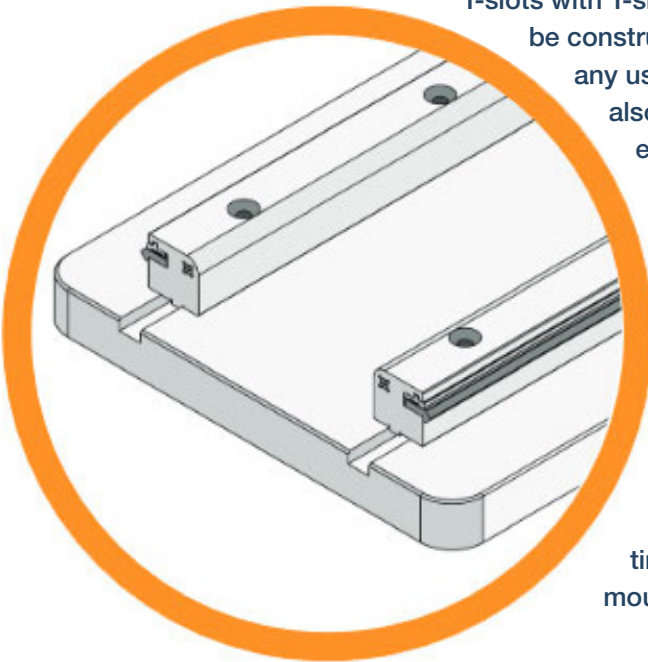

Figure 5. Machined Channels

CONCLUSIONS

A wide variety of linear motion product types are available for industrial equipment builders and designers to add linear guide features to their systems. A properly selected product can reduce the time, cost and difficulty of system development and production.

The usage of standardized, modular components like T-slot profile extrusions (Figure 1) instead of customer fabricated parts has enabled industrial equipment to be designed, assembled and modified more quickly and easily than ever before. By the same principle, linear guide products developed with modular system design and assembly characteristics, like QuickTrak, can likewise permit linear guidance capabilities to be more easily incorporated into equipment

About

Bishop-Wisecarver develops innovative motion solutions that are expertly designed and delivered to perform from a company you can trust. Leveraging nearly 70 years of experience, we've earned the reputation of providing unmatched quality, reliable service and engineering support for every stage of a customer's design cycle. No matter your application, volume shipment requirements or extreme environmental conditions, Bishop-Wisecarver listens to your specific needs and delivers innovative solutions.