



HIGH LOAD
CAPACITY



LOW
MAINTENANCE



LONG LENGTHS



CUSTOMIZABLE

ROBOT TRANSFER SYSTEM

Automation - Robotics

CUSTOMER & APPLICATION:

The Gear Robot System (GRS) developed and patented by Lucas Robotics France is a revolutionary solution to ensure robots are always in the right place at the right time.

GRS makes it possible to build flexible computerized systems where the robots can be transferred to a specific production or assembly line track using the most space efficient layout for the factory.

Lucas needed a Heavy Duty routing system comprising a centralized length of track 2m long where robots are positioned prior to being transferred. Track lengths are typically 10-20m long.

CHALLENGE:

Transferring a 2 ton robot from a centralized station to a remote track by first rotating the holding station up to 360 degrees and lining up with a track introduces a number of technical challenges. Unless guides and drive racks are aligned exactly, making the transfer would be difficult if not impossible without damaging the system.

SCOPE OF SUPPLY

HDS2 Heavy Duty Linear Guide System

- CHSS25NK/CHSS33NK single edge vee slides with rack drive, cut to length
- THJR vee guide bearings (size 95, 120, or 150 depending on robot)

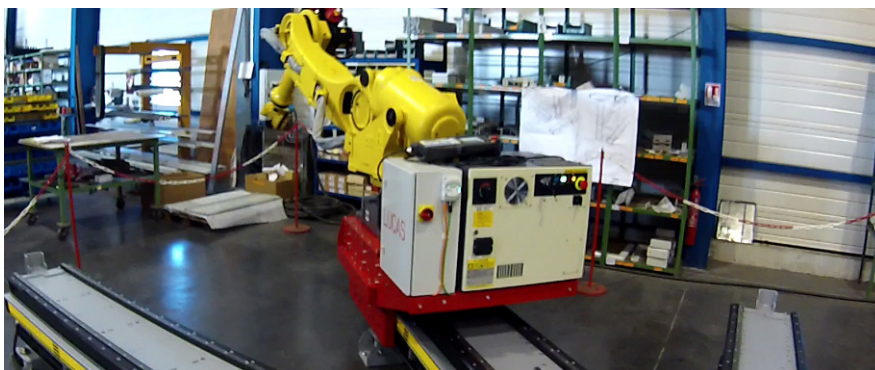

The GRS can move cartesian, polyarticulated, and hybrid motion robots

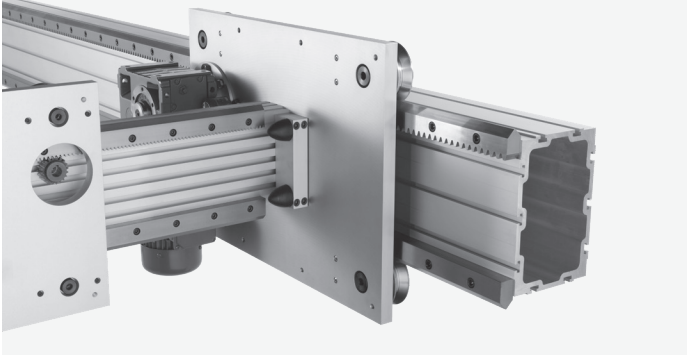

HDS2 Heavy Duty Slide System in a multi-axis configuration



HDS2 Heavy Duty Slide components, showing a rack and pinion drive

SOLUTION:

Lucas used their own proprietary steel construction beam and fit HepcoMotion® HDS2 guides CHSS25NK in parallel spaced apart 350mm. The central rotating station at 2m long is shorter than the gap between opposing tracks to allow rotation. This means that having rotated the station to line up with the requisite track, it has to be indexed to butt to the mating track so the transfer can take place. This is achieved by a clever cam mechanism that locates in the central station and pulls the whole station towards the track until it makes contact.

For the main assembly tracks the precision CHSS25 NK – HDS2 guides are available in lengths up to 4m in one piece, and for longer lengths they can be butted. Vee guide wheels can easily traverse small gaps between butt-joined tracks, but the 2m guide lengths on the central station are still machined to minimize gaps when the central station is indexed.

At the end of the guides, HepcoMotion machine an angle in two planes so that the vee bearing will cross an angled butt joint as opposed to a square butt joint. The angled joint, tight size control of the vee profile, and guides of matching lengths ensure a successful transfer operation.

RESULTS:

The whole system is very low maintenance. Vee technology only requires small amounts of lubricant to spread over the vee guide surfaces to achieve a long and trouble free life. Low maintenance cap wipers are fitted to completely cover the bearings preventing the ingress of dirt and apply the lubrication. With the cap wiper felts soaked in oil they will perform for long periods without the need for re-lubrication. In most cases, grease is supplied as the lubricant and the action of the bearing rotating within the cap seal effectively liquefies the grease and feeds the lubricators.

With such high duty robot assembly systems the HepcoMotion standard bleed lubrication system fitted to the guides with time regulated canister will ensure no maintenance for at least 6 months.

The Gear Robot System can handle payloads from 100kg to 6 tons. Within the medium load range, HDS2 guides with vee bearings 95, 120 or even 150mm diameter are used. For the top load range the HepcoMotion MHD system which uses large diameter rollers on hardened and ground flat track will offer a higher load capacity with many of the inherent benefits of HDS2.

GRS is targeted as an innovative solution for moving cartesian, polyarticulated and “hybrid motion” robots, however, potential users will find the principle of the system highly useful as a means of feeding parts to specific production lines. This sort of application can be seen in many production facilities, the robot could easily be replaced with a tooling fixture or carrier for storing components.

For robot transfer units, gantry systems, and 7th axis robotic applications, Bishop-Wisecarver offers a variety of actuated guide systems including HepcoMotion® HDS2 and MHD. Bishop-Wisecarver has been the exclusive North American distributor of HepcoMotion products since 1984.

CONTACT US TO DISCUSS YOUR SPECIFIC GUIDED MOTION NEEDS

925.439.8272 | BWC.COM